

DYVA 东盐阀门  
DONGYAN VALVE  
国阀品质 东盐匠心  
NATIONAL VALVE QUALITY DONGYAN CRAFTSMANSHIP

## AMERICAN STANDARD VALVE SERIES 美标阀门系列

为各领域提供全套阀门解决方案!

聚焦客户关注的挑战和压力,提供有竞争力的工程产品和高品质的工程服务,持续为客户创造最大价值。

### 设计

法兰闸阀为提供最大的操作寿命和可靠性而设计和生产的,所有的闸阀都符合美国石油学会标准; AP1600&AP16D的要求,英标BS1414和BSEN1984的标准。与美国机械工程师学会标准ASME16.34一致,阀门由完整的阀体、阀盖、内件组成。

### Design

flange gate valve are designed and manufactured to provide maximum service life and dependability. All gate valves are full ported and meet the design requirements of American petroleum Institute Standard Ap1600&AP16D, British Standard BS 1414&BS EN 1984 and generally conform to American Society of Mechanical Engineers Standard ASME B 16.34. Valves are available in a complete range of body/bonnet materials and trims.

### 材料范围

阀体/阀盖的材料包括碳含量的九个等级,低合金和不锈钢,在特殊的适用中,他们可用合金和不锈钢的其他等级。有许多内件供不同的环境下使用。填料和垫片的选择也为各种环境所具备。

### Range of Materials

Standard body/bonnet materials include nine grades of carbon, low alloy and stainless steels. For special applications they can be supplied in other grades of alloy and stainless steel. There's a full range of trim materials to match any service. Optional packing and gasket materials are available for a full range of service conditions.

### 阀门的商标可以按照客户的要求修改 Available Modifications For Trademark Cast Valves

- |          |                               |            |   |
|----------|-------------------------------|------------|---|
| *内件变化    | *Trim changes                 | *压力调节      | *Pressure Equalizing                    |
| *法兰连接改变  | *End connection Modifications | *旁通管       | *By-pass                                |
| *填料和垫片改变 | *Packing and Gasket Changes   | *客户特殊的铸造要求 | *Customer specified Coatings            |
| *操作装置    | *Operator Mounting            | *改变(法兰孔数)  | *Weld End Bore Changes                  |
| *手轮延展    | *Handwheel Extensions         | *氧或氯气清洁和包装 | *Oxygen & Chlorine Cleaning & Packaging |

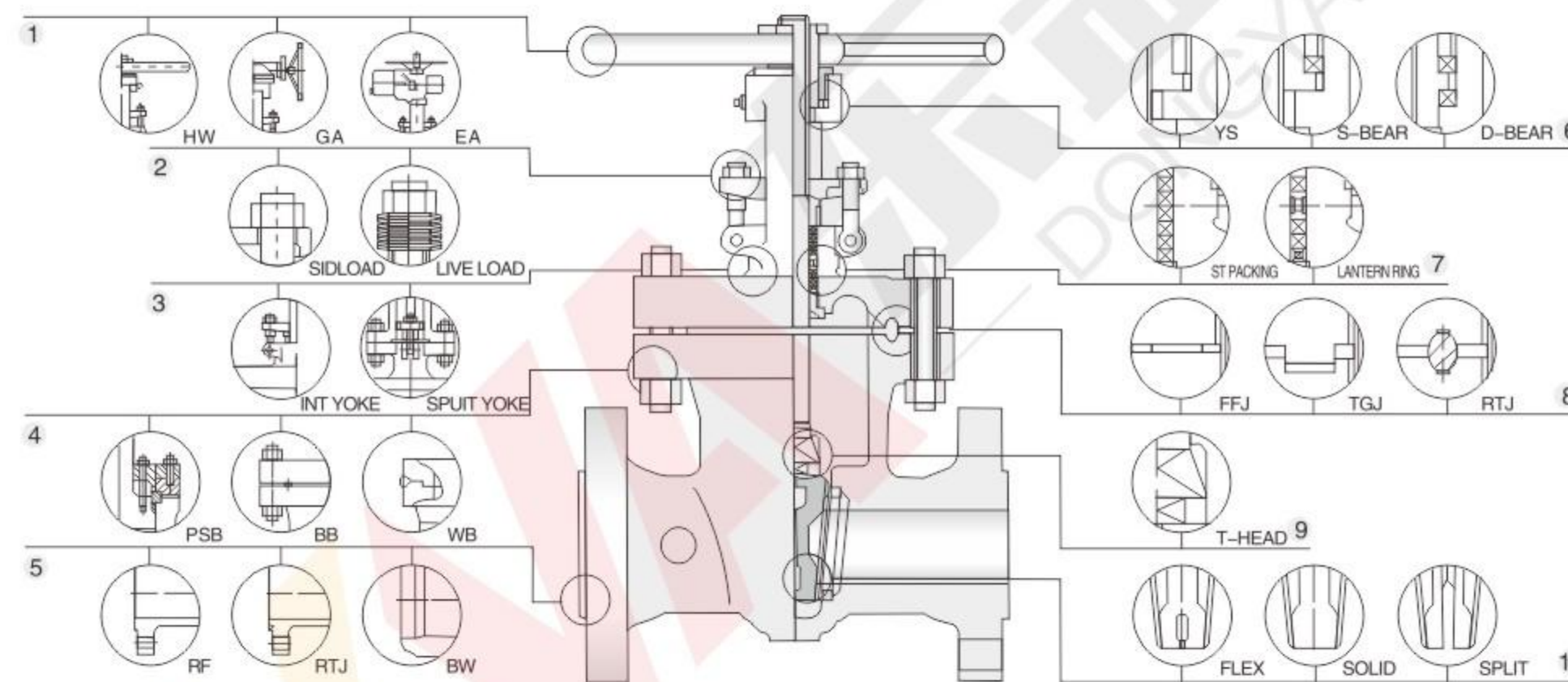

### 1. 操作 Operating

大手轮使得更容易操作,同样也可以用齿轮或电动操作,气动、液动用于更艰难的环境。  
Large hand wheels for easy operation. Also available with gearing, motor actuators, pneumatic or hydraulic actuators for more difficult services.

### 2. 填料

填料在高温高压的变更的情况下,使用很频繁,填料调节环提供连续的填料压盖压力。在负荷期间可以通过增加填料来调节填料压盖的抑紧力。  
In services requiring frequent cycling or with high pressure/temperature variations, live loading extends the service life between maintenance periods by requiring less frequent packing gland adjustments. Belleville springs are employed to provide constant packing gland stress.

### 3. 明杆支架 OS & Y

外螺纹支架、铸钢闸阀支架在150Lb-8", 300Lb-8", 600Lb-8", 900Lb-4"以下的为整体阀盖。  
Outside Screw and Yoke. Cast steel gate valve yoke. Integral with bonnet for 150Lb-8", 300Lb-8", 600Lb-8", 900Lb-4" & small.

### 4. 螺栓连接 BB

螺栓阀盖、对焊接阀盖,压力自密封阀座在高温高压变更的情况下采用周期的检修服务。  
Bolted bonnet. Welding bonnet and pressure seal bonnet in services requiring frequent cycling or with high pressure/temperature variations.

### 5. 连接方式

可采用法兰连接、环连接、对接焊管件。  
A choice of Flanged, RTJ flanged or Butt welding end for piping flexibility

### 6. 支架套

加长的支架套和阀杆提供加长阀门尺寸大于150Lb-12", 300Lb-10", 600Lb-6", 900Lb/1500Lb/2500Lb-4"的采用滚动轴承支架。  
Extra long thread engagement between yoke sleeve and stem provide long thread life. Valves of sizes larger than 150Lb-12", 300Lb-10", 600Lb-6", 900Lb/1500Lb/2500Lb-4" are regularly provided with roll bearing yokes.

### 7. 隔离环和双填料

隔离环渗漏连接和双填料依临界选择。  
Lantern ring with leak-off fitting connection and double packing stack is optionally available for critical services.

### 8. 阀体 - 阀盖连接

包边垫用于150磅的阀门, 弹性垫用于300磅到600磅的阀门, 环连接用于900磅或更高的等级。  
A flat face gasket joint is used in the 150Lb valves. A male and female joint is used in 300Lb to 600Lb valves. Ring joint is used in the body to bonnet connection in 900Lb & higher rated valves.

### 9. 阀杆 Stem

全部的模式闸阀以"T"型锻造阀杆形式,通过"T"型锻造,在阀杆上,阀板的连接是自身加固形式,这种设计也适用闸板自动调节,除去双闸板可能造成的干扰因素。  
All wedge gate valves are provided with upset forged T-head stems. By forging the T-head, the stem at the stem-wedge connection is strengthened. This design also allows the wedge to self-align, eliminating the possibility of bent stem jamming the wedge.

### 10. 闸板 Wedge

完整的操作表面确保闸板自身位于中间,弹性楔式闸板有单片、双片式闸板,它们的设计每个都是半弹性独立的,适用于实心闸板、双闸板和弹性闸板。  
Integral guide rib faces assure self-centering of wedge. Flexible wedge gate valve has a one-piece, twin-disc wedge, which is designed so that each half flexes independently. Available in solid, flex split and HIs designs.



### 1、概述

我公司生产的美标闸阀，完全按照美国标准设计制造，结构美观、先进，阀门的启闭件是闸板，闸板的运动方向与流体方向相垂直，闸阀只能作全开和全关，不能作调节和节流，闸板有两个密封面，楔形角为2° 52'。楔式闸阀的闸板可以做成一个整体，叫做刚性闸板；也可以做成能产生微量变形的闸板，以改善其工艺性，弥补密封面角度在加工过程中产生的偏差，这种闸板叫做弹性闸板。

### 2、性能参数 Performance parameter

序号	项目名称	项目名称					
		150(Lb)	300(Lb)	600(Lb)	900(Lb)	1500(Lb)	2500(Lb)
1	公称压力PN (MPa)	2.0	5.0	10.0	15.0	25.0	45.0
2	壳体强度试验压力 Case Test pressure (MPa)	3.0	7.5	15.0	22.5	37.5	67.5
3	高压密封试验压力 High-pressure sealing Test pressure (MPa)	2.2	5.5	11.0	16.5	27.5	49.5
4	常温下工作压力Maximum teperature Working pressure (MPa)	≤2.0	≤5.2	≤10.4	≤15.6	≤25.8	≤45.8

### 3、产品规范Product specification

设计标准 Design	结构长度 Structure Length	法兰连接尺寸 Connection flange	试验与检验 Test and Inspection	压力与温度基准 ASME B16.34
API 600	ASME B16.10	ASME B16.5	API 598	ASME B16.34

### 主要零件材料Main components material

零件名称Part Name	材料名称 Material name					
阀体Body	A216 WCB	A217 WC6	A351 CF8	A351 CF8M	A351 CF3	A351 CF3M
阀盖Valve cover	A216 WCB	A217 WC6	A351 CF8	A351 CF8M	A351 CF3	A351 CF3M
闸板valve plate	A216 WCB	A217 WC6	A351 CF8	A351 CF8M	A351 CF3	A351 CF3M
密封面sealing face	2Cr13	STL	本体/STL	本体/STL	本体/STL	本体/STL
阀杆Stem	A182 F6a	A182 F11	A182 F304	A182 F316	A182 F304L	A182 F316L
垫片	304+柔性石墨	304+柔性石墨	304+柔性石墨	304+柔性石墨	304+柔性石墨	304+柔性石墨
螺栓	A193 B7	A193 B7	A193 B8	A193 B8M	A193 B8M	A193 B8M
螺母 Nut	A194 2H	A194 6	A194 8	A194 8M	A194 8M	A194 8M
使用温度	-29~425℃	-29~540℃	-46~425℃	-46~425℃	-46~425℃	-46~425℃
适用介质	水、蒸汽、油品等	水、蒸汽等	硝酸类弱腐蚀介质	硝酸类弱腐蚀介质	硝酸类弱腐蚀介质	硝酸类弱腐蚀介质

### Z40H、Z40Y、Z40W型150 (Lb)~2500 (Lb)美标楔式闸阀

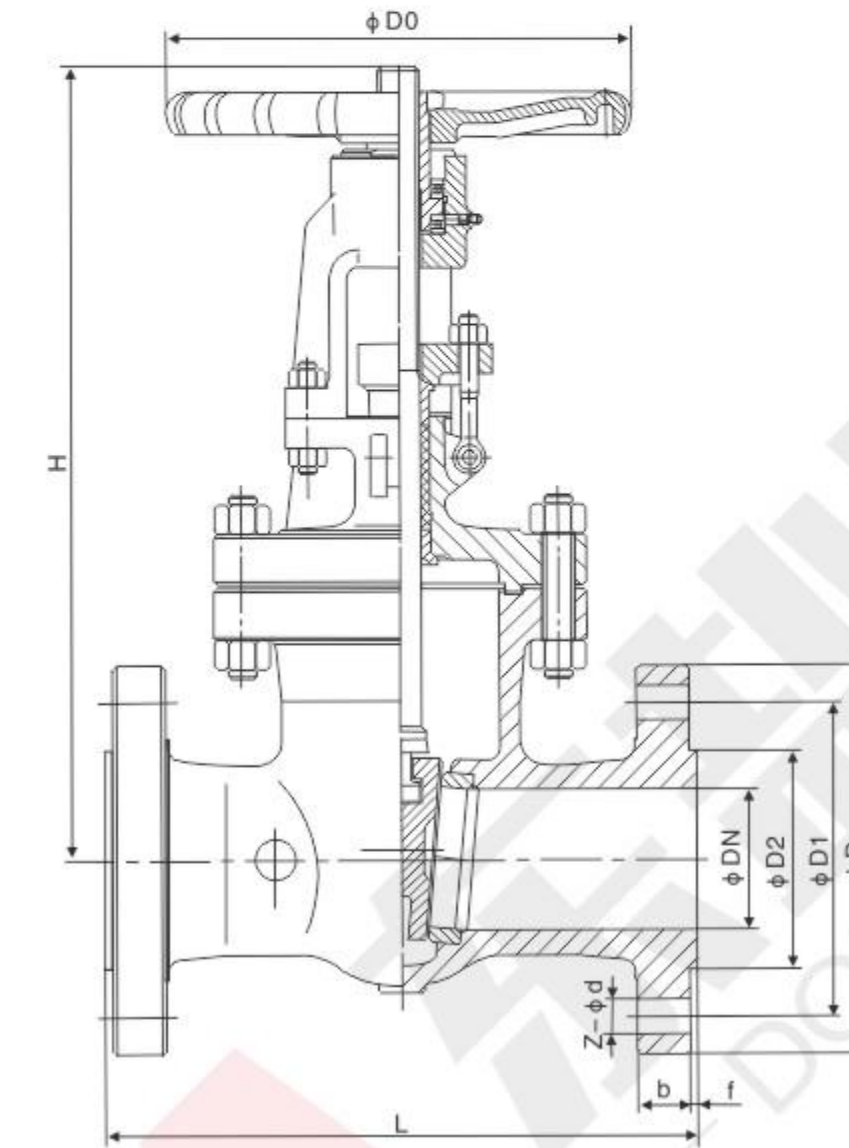

### 尺寸数据 Dimensions data

DN	DN/in	L	D	D1	D2	b	z x phi d	H≈	Do≈	重量/kg
150(Lb)										
15	1/2	108	90	60.5	35	12	4 x phi 15	188	90	-
20	3/4	117	100	70	43	12	4 x phi 15	202	90	-
25	1	127	110	79.5	51	12	4 x phi 15	225	100	-
32	1 1/4	140	115	89	64	13	4 x phi 15	252	100	-
40	1 1/2	165	125	98.5	73	15	4 x phi 15	277	140	-
50	2	178	150	120.5	92	16	4 x phi 19	323	200	23
65	2 1/2	190	180	139.5	105	18	4 x phi 19	347	250	32
80	3	203	190	152.5	127	19	4 x phi 19	383	250	40
100	4	229	230	190.5	157	24	8 x phi 19	457	300	63
125	5	254	255	216	185.7	24	8 x phi 22	632	300	66
150	6	267	280	241.5	216	26	8 x phi 22	635	350	108
200	8	292	345	298.5	270	29	8 x phi 22	762	350	171
250	10	330	405	362	324	31	12 x phi 25	895	400	263
300	12	356	485	432	381	32	12 x phi 25	1080	500	346
350	14	381	535	476	413	35	12 x phi 29	1295	600	488
400	16	406	595	540	470	37	16 x phi 29	1435	600	621
450	18	432	635	578	533.4	40	16 x phi 32	1626	650	814
500	20	457	700	635	584	43	20 x phi 32	1829	650	992
600	24	508	815	749.5	692	48	20 x phi 35	2175	700	1492
750	30	610	985	914.5	857	75	28 x phi 35	2692	700	2272
800	32	660	1060	978	914.4	81	28 x phi 41	3281	-	2480
900	36	711	1170	1085.9	1022	90	32 x phi 41	3721	-	3310



尺寸数据 Dimensions data

DN	DN/in	L	D	D <sub>1</sub>	D <sub>2</sub>	b	z × φ d	H≈	Do≈	重量/kg
300(Lb)										
15	1/2	140	95	66.5	35	15	4 × φ 15	155	100	3.7
20	3/4	152	115	82.5	43	16	4 × φ 19	160	100	4.3
25	1	165	125	89	51	18	4 × φ 19	186	125	7.1
32	1 1/4	178	135	98.5	63	19	4 × φ 19	216	160	-
40	1 1/2	190	155	114.5	73	21	4 × φ 22	250	160	13.1
50	2	216	165	127	92	22	8 × φ 19	330	250	30
65	2 1/2	241	190	149	105	25	8 × φ 22	368	250	36
80	3	283	210	168.5	127	29	8 × φ 22	394	300	61
100	4	305	255	200	157	32	8 × φ 22	473	300	77
125	5	381	280	235	186	35	8 × φ 22	660	350	106
150	6	403	320	270	216	37	12 × φ 22	711	350	153
200	8	419	380	330	270	41	12 × φ 25	813	400	286
250	10	457	445	387.5	324	48	16 × φ 29	1003	500	412
300	12	502	520	451	381	51	16 × φ 32	1137	600	576
350	14	762	585	514.5	413	54	20 × φ 32	1489	600	886
400	16	838	650	571.5	470	57	20 × φ 35	1581	650	1175
450	18	914	710	628.5	533	60	24 × φ 35	2017	838	1301
500	20	991	775	686	584	64	24 × φ 35	2228	889	1672
600	24	1143	915	813	692	70	24 × φ 41	2650	1092	2562

尺寸数据 Dimensions data

DN	DN/in	L	D	D <sub>1</sub>	D <sub>2</sub>	b	z × φ d	H≈	Do≈	重量/kg
600(Lb)										
15	1/2	165	95	66.5	35	22	4 × φ 15	155	100	3.8
20	3/4	190	120	82.5	43	23	4 × φ 19	160	100	5.4
25	1	216	125	89	51	25	4 × φ 19	186	125	7.6
32	1 1/4	229	135	98.5	63	28	4 × φ 19	216	160	10
40	1 1/2	241	155	114.5	73	30	4 × φ 22	250	160	15
50	2	292	165	127	92	33	8 × φ 19	510	254	44
65	2 1/2	330	190	149	100	36	8 × φ 22	554	254	60
80	3	356	210	168	127	39	8 × φ 22	595	305	80
100	4	432	275	216	157	45	8 × φ 25	712	356	145
125	5	508	330	266.5	186	52	8 × φ 29	826	406	236
150	6	559	355	292	216	55	12 × φ 29	995	508	309
200	8	660	420	349	270	63	12 × φ 32	1157	610	522
250	10	787	510	432	324	71	16 × φ 35	1373	686	779
300	12	838	560	489	381	74	20 × φ 35	1603	686	1108
350	14	889	605	527	413	77	20 × φ 38	1930	762	1503
400	16	991	685	603	470	84	20 × φ 41	2032	889	1939
450	18	1092	745	654	533	90	20 × φ 44	2286	889	2733
500	20	1194	815	724	584	96	24 × φ 44	2591	1118	3214
600	24	1397	940	838	692	109	24 × φ 52	3124	1118	4177

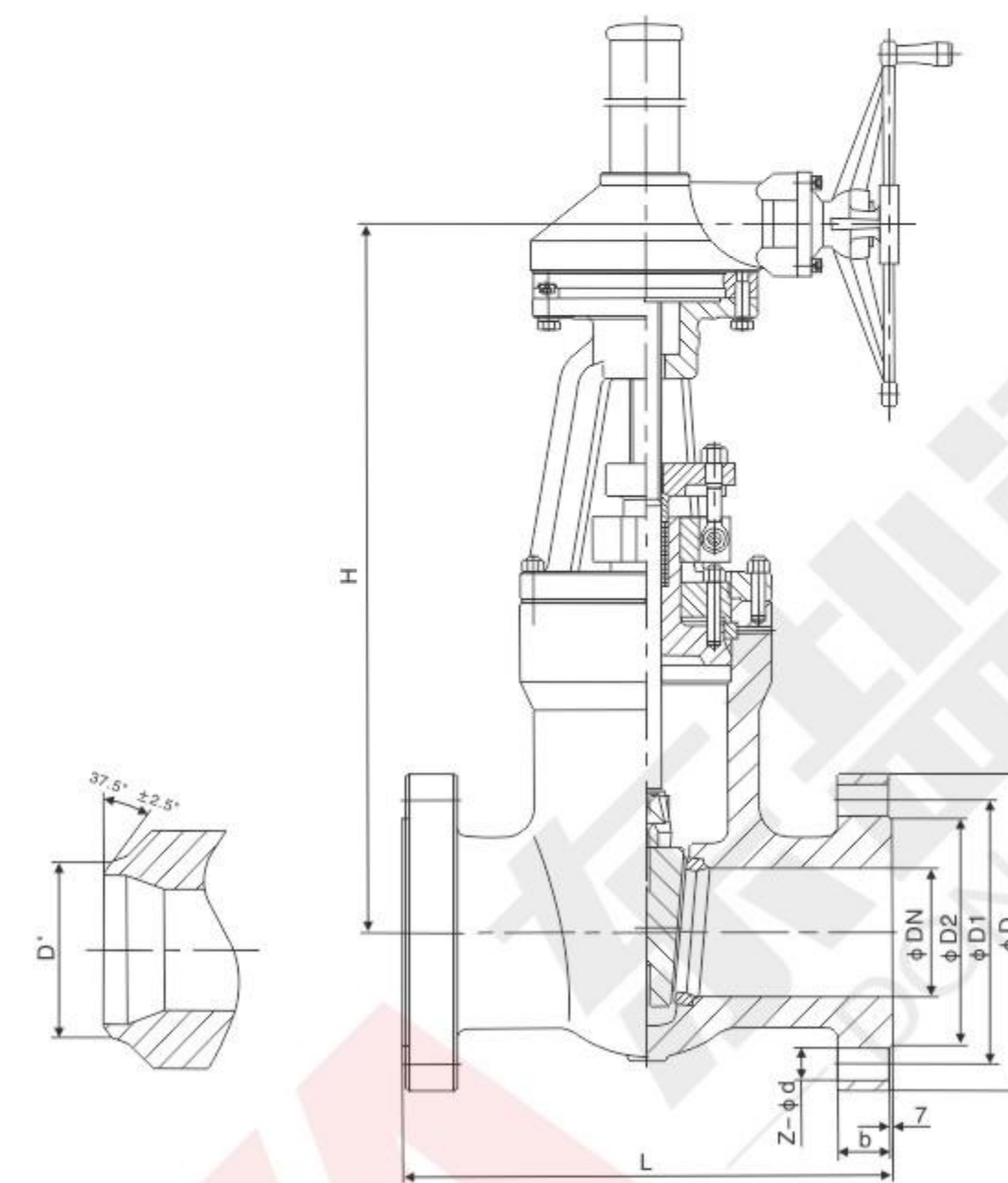

尺寸数据 Dimensions data

DN	DN/in	L	D	D <sub>1</sub>	D <sub>2</sub>	b	z × φ d	D'	H	Do
900(Lb)										
50	2	368	215	165.1	92	34.8	8 × φ 25.5	60.5	465	250
80	3	381	240	190.5	127	44.4	8 × φ 25.5	89.1	625	300
100	4	457	290	235	157	50.9	8 × φ 32	114.3	855	350
150	6	610	380	317.5	216	62.4	12 × φ 32	168	1195	450
200	8	737	470	393.7	270	69.9	12 × φ 38	216	1220	500
250	10	838	545	469.9	324	76.4	16 × φ 38	260	1440	550
300	12	965	610	533.4	381	85.4	20 × φ 38	323.5	1622	600
1500(Lb)										
50	2	368.5	215	165.1	92	44.9	8 × φ 25.5	60.5	465	350
80	3	470	265	203.2	127	54.4	8 × φ 32	89.1	625	450
100	4	546	310	241.3	157	60.4	8 × φ 35	114.3	800	500
150	6	705	395	317.5	216	89.4	12 × φ 38	168	1200	450
200	8	832	485	393.7	270	98.4	12 × φ 45	216	1220	500
250	10	991	585	482.6	324	114.4	12 × φ 51	260	1440	550
300	12	1130.5	670	571.5	381	130.4	16 × φ 54	323.5	1622	600
2500(Lb)										
50	2	451	235	171.5	92	57.2	8 × φ 28.5	60.5	523	350
80	3	578	305	228.6	127	72.9	8 × φ 35	89.1	715	500
100	4	673	355	273	157	82.6	8 × φ 41.5	114.3	861	600
150	6	914.5	485	368.3	216	114.4	8 × φ 54	168	1105	600



### 1、概述

我公司生产的美标截止阀，完全按照美国标准设计制造，结构美观、先进。阀门的启闭件是阀瓣，流向为低进高出，截止阀全开和全关阀杆来操作阀门，锥形的阀瓣可以很好的起到节流作用，不能起调节作用。主要用于石油、化工、制药、化肥、电力行业等各种工况的管路上，切断或接通管路介质。驱动方式有手动、齿轮传动、电动、气动等。

### 2、性能参数 Performance parameter

序号	项目名称	项目名称					
		150(Lb)	300(Lb)	600(Lb)	900(Lb)	1500(Lb)	2500(Lb)
1	公称压力PN (MPa)	2.0	5.0	10.0	15.0	25.0	45.0
2	壳体强度试验压力 Case Test pressure (MPa)	3.0	7.5	15.0	22.5	37.5	67.5
3	高压密封试验压力 High-pressure sealing Test pressure (MPa)	2.2	5.5	11.0	16.5	27.5	49.5
4	常温下工作压力Maximum teperature Working pressure (MPa)	≤2.0	≤5.2	≤10.4	≤15.6	≤25.8	≤45.8

### 3、产品规范Product specification

设计标准 Design	结构长度 Structure Length	法兰连接尺寸 Connection flange	试验与检验 Test and Inspection	压力与温度基准 ASME B16.34
Bs1873	ASME B16.10	ASME B16.5	API 598	ASME B16.34

### 主要零件材料Main components material

零件名称Part Name	材料名称 Material name					
阀体Body	A216 WCB	A217 WC6	A351 CF8	A351 CF8M	A351 CF3	A351 CF3M
阀盖Valve cover	A216 WCB	A217 WC6	A351 CF8	A351 CF8M	A351 CF3	A351 CF3M
阀板valve plate	A216 WCB	A217 WC6	A351 CF8	A351 CF8M	A351 CF3	A351 CF3M
密封面sealing face	2Cr13	STL	本体/STL	本体/STL	本体/STL	本体/STL
阀杆Stem	A182 F6a	A182 F11	A182 F304	A182 F316	A182 F304L	A182 F316L
垫片	304+柔性石墨	304+柔性石墨	304+柔性石墨	304+柔性石墨	304+柔性石墨	304+柔性石墨
螺栓	A193 B7	A193 B7	A193 B8	A193 B8M	A193 B8M	A193 B8M
螺母Nut	A194 2H	A194 6	A194 8	A194 8M	A194 8M	A194 8M
使用温度	-29~425℃	-29~540℃	-46~425℃	-46~425℃	-46~425℃	-46~425℃
适用介质	水、蒸汽、油品等	水、蒸汽等	硝酸类弱腐蚀介质	硝酸类弱腐蚀介质	硝酸类弱腐蚀介质	硝酸类弱腐蚀介质

### J41H、J40Y、J41W型150 (Lb)~2500 (Lb)

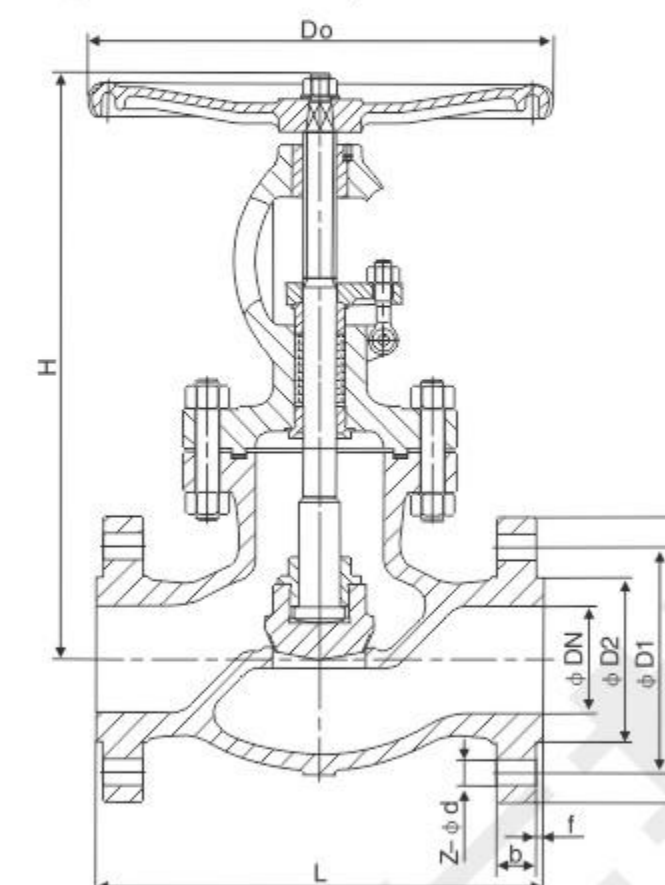

### 尺寸数据 Dimensions data

DN	DN/in	L	D	D <sub>1</sub>	D <sub>2</sub>	b	z × φd	H	Do	重量/kg
150(Lb)										
15	1/2	108	90	60.5	35	10	4 × φ15	241	125	-
20	3/4	117	100	70	43	11	4 × φ15	241	125	-
25	1	127	110	79.5	51	12	4 × φ15	242	125	-
32	1 1/4	140	120	89	63	13	4 × φ15	280	160	-
40	1 1/2	165	130	98.5	73	15	4 × φ15	286	160	-
50	2	203	150	120.5	92	16	4 × φ19	368	200	18
65	2 1/2	216	180	139.5	105	18	4 × φ19	387	200	30
80	3	241	190	152.5	127	19	4 × φ19	411	250	41
100	4	292	230	190.5	157	24	8 × φ19	454	250	64
125	5	356	255	216	186	24	8 × φ22	455	355	86
150	6	406	280	241.5	216	26	8 × φ22	541	355	113
200	8	495	345	298.5	270	29	8 × φ22	651	450	115
250	10	622	405	362	324	31	12 × φ25	800	450	178
300	12	698	485	432	381	32	12 × φ25	1231	500	264
350	14	787	535	476.5	413	35	12 × φ29	1450	600	370
400	16	914	595	534.5	470	37	16 × φ29	1645	600	500
450	18	-	635	577.5	533	40	16 × φ32	-	610	1400
300(Lb)										
15	1/2	152	95	66.5	35	15	4 × φ15	241	125	-
20	3/4	178	120	82.5	43	16	4 × φ19	241	125	-
25	1	203	125	89	51	18	4 × φ19	283	160	-
32	1 1/4	216	135	98.5	63	19	4 × φ19	320	200	-
40	1 1/2	229	155	114.3	73	21	4 × φ22	322	200	-
50	2	267	165	127	92	23	8 × φ19	399	200	25
65	2 1/2	292	190	149	105	26	8 × φ22	438	250	30
80	3	318	210	168.5	127	29	8 × φ22	464	280	35
100	4	356	255	200	157	32	8 × φ22	565	355	56
125	5	400	280	235	186	35	8 × φ22	614	400	96
150	6	444	320	270	216	37	12 × φ22	717	450	120
200	8	559	380	330	270	42	12 × φ25	930	500	212
250	10	622	445	387.5	324	47.7	16 × φ29	1012	450	330
300	12	711	520	451	381	50.8	16 × φ32	1231	500	472
350	14	762	585	514.5	413	54	20 × φ32	1450	600	715
400	16	864	650	571.5	470	57.2	20 × φ35	1645	600	920



尺寸数据 Dimensions data

DN	DN/in	L	D	D <sub>1</sub>	D <sub>2</sub>	b	z × φd	H≈	Do≈	重量/kg
600(Lb)										
15	1/2	165	95	66.5	35	22	4 × φ15	100	156	-
20	3/4	190	120	82.5	43	23	4 × φ19	100	161	-
25	1	216	125	89	51	25	4 × φ19	125	187	-
32	1 1/4	229	135	98.5	63	28	4 × φ19	160	214	-
40	1 1/2	241	155	114.3	73	30	4 × φ22	160	252	-
50	2	292	165	127	92	33	8 × φ22	180	430	35
65	2 1/2	330	190	149	100	36	8 × φ22	250	480	50
80	3	356	210	168	127	39	8 × φ22	250	530	60
100	4	432	275	216	157	45	8 × φ25	350	650	110
125	5	508	330	266.5	186	52	8 × φ29	350	750	200
150	6	559	355	292	216	55	12 × φ29	450	850	230
200	8	660	420	349	270	63	12 × φ32	500	1050	410
250	10	787	510	432	324	71	16 × φ35	600	1257	625
300	12	838	560	489	381	74	20 × φ35	680	1468	960
350	14	889	605	527	413	77	20 × φ38	760	1623	1300
400	16	991	685	603	470	84	20 × φ41	760	1816	1590
900(Lb)										
50	2	368	216	165	92	46	8 × φ26	569	320	65
65	2 1/2	419	244	191	105	49	8 × φ29	569	320	75
80	3	381	241	191	127	46	8 × φ26	604	360	105
100	4	457	292	235	157	52	8 × φ32	708	450	165
125	5	559	349	279	186	58	8 × φ35	780	560	260
150	6	610	381	318	216	63	12 × φ32	890	630	330
200	8	737	470	394	270	71	12 × φ29	1240	720	690
250	10	838	545	470	324	77	16 × φ39	1651	760	1300
1500(Lb)										
65	2 1/2	419	244	190	105	42	8 × φ29	461	400	65
80	3	470	267	203	127	48	8 × φ32	554	450	95
100	4	546	311	241	157	54	8 × φ35	639	500	155
125	5	673	375	292	186	74	8 × φ42	780	560	240
150	6	705	394	318	216	83	12 × φ39	904	630	400
200	8	832	483	394	270	93	12 × φ45	1140	560	640
2500(Lb)										
65	2 1/2	508	267	197	125	65	8 × φ32	492	400	82
80	3	578	305	229	127	74	8 × φ35	59	450	112
100	4	673	356	273	157	84	8 × φ42	715	560	230
125	5	794	419	324	186	100	8 × φ48	830	630	400
150	6	914	483	368	216	115	8 × φ54	1070	560	650
200	8	890	550	438	270	134	12 × φ54	1180	630	1100

1、概述

我公司生产的美标止回阀，完全按照美国标准设计制造，结构美观、先进。美标止回阀是指依靠介质本身流动而自动开、闭阀瓣，用来防止介质倒流的阀门，又称逆止阀、单向阀、逆流阀。止回阀属于一种自动阀门，其主要作用是防止介质倒流、防止泵及驱动电动机反转，以及容器介质的泄放。

2、性能参数 Performance parameter

序号	项目名称	项目名称					
		150(Lb)	300(Lb)	600(Lb)	900(Lb)	1500(Lb)	2500(Lb)
1	公称压力PN (MPa)	2.0	5.0	10.0	15.0	25.0	45.0
2	壳体强度试验压力 Case Test pressure (MPa)	3.0	7.5	15.0	22.5	37.5	67.5
3	高压密封试验压力 High-pressure sealing Test pressure (MPa)	2.2	5.5	11.0	16.5	27.5	49.5
4	常温下工作压力Maximum teperature Working pressure (MPa)	≤2.0	≤5.2	≤10.4	≤15.6	≤25.8	≤45.8

3、产品规范Product specification

设计标准 Design	结构长度 Structure Length	法兰连接尺寸 Connection flange	试验与检验 Test and Inspection	压力与温度基准 ASME B16.34
BS1868	ASME B16.10	ASME B16.5	API 598	ASME B16.34

主要零件材料Main components material

零件名称Part Name	材料名称 Material name					
阀体Body	A216 WCB	A217 WC6	A351 CF8	A351 CF8M	A351 CF3	A351 CF3M
阀盖Valve cover	A216 WCB	A217 WC6	A351 CF8	A351 CF8M	A351 CF3	A351 CF3M
阀板valve plate	A216 WCB	A217 WC6	A351 Cf8	A351 CF8M	A351 CF3	A351 CF3M
密封面sealing face	2Cr13	STL	本体/STL	本体/STL	本体/STL	本体/STL
阀轴	A182 F6a	A182 F11	A182 F304	A182 F316	A182 F304L	A182 F316L
垫片	304+柔性石墨	304+柔性石墨	304+柔性石墨	304+柔性石墨	304+柔性石墨	304+柔性石墨
螺栓	A193 B7	A193 B7	A193 B8	A193 B8M	A193 B8M	A193 B8M
螺母	A194 2H	A194 6	A194 8	A194 8M	A194 8M	A194 8M
使用温度	-29~425℃	-29~540℃	-46~425℃	-46~425℃	-46~425℃	-46~425℃
适用介质	水、蒸汽、油品等	水、蒸汽等	硝酸类弱腐蚀介质	硝酸类弱腐蚀介质	硝酸类弱腐蚀介质	硝酸类弱腐蚀介质



H44H、H44Y、H44W型150 (Lb)~2500 (Lb)

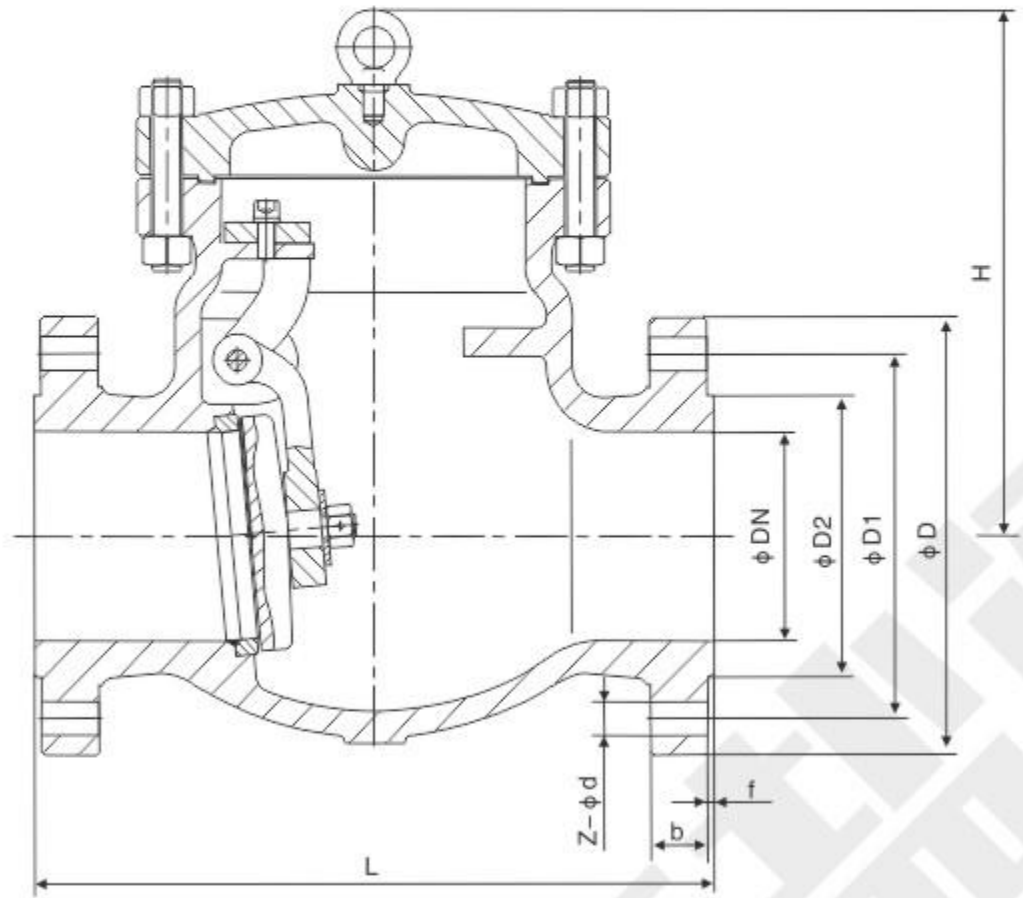

尺寸数据 Dimensions data

DN	DN/in	L	D	D <sub>1</sub>	D <sub>2</sub>	b	z x φ d	H	重量/kg
150(Lb)									
40	1 1/2	165	130	98.5	73	15	4 x φ 15	154	-
50	2	203	150	120.6	92	19	4 x φ 19	161	17
65	2 1/2	216	180	139.7	105	22	4 x φ 19	180	23
80	3	241	190	152.4	127	24	4 x φ 19	190	33
100	4	292	230	190.5	157	24	8 x φ 19	203	44
125	5	330	255	215.5	186	24	8 x φ 22	229	62
150	6	356	280	241.3	216	25	8 x φ 22	257	78
200	8	495	345	298.4	270	29	8 x φ 22	292	137
250	10	622	405	362.0	324	30	12 x φ 25	355	207
300	12	698	485	431.8	381	32	12 x φ 25	396	279
350	14	787	535	476.2	413	35	12 x φ 29	445	387
400	16	864	595	539.8	470	37	16 x φ 29	490	446
450	18	978	635	577.8	533	40	16 x φ 32	520	621
500	20	978	700	635.0	584	43	20 x φ 32	546	770
600	24	1295	815	749.3	692	48	20 x φ 35	880	970
650	26	1295	870	806.4	749	68	24 x φ 35	910	1276
700	28	1448	925	863.6	800	71	28 x φ 35	935	1600
750	30	1524	985	914.4	857	75	28 x φ 35	970	1990

尺寸数据 Dimensions data

DN	DN/in	L	D	D <sub>1</sub>	D <sub>2</sub>	b	z x φ d	H	重量/kg
300(Lb)									
40	-	241	155	114.5	73	21	4 x φ 22	172	-
50	2	267	165	127.0	92	22	8 x φ 19	178	20
65	2 1/2	292	190	149.4	105	25	8 x φ 22	190	24
80	3	318	210	168.1	127	29	8 x φ 22	216	40
100	4	356	255	200.2	157	32	8 x φ 22	241	51
125	5	400	280	235.0	186	35	12 x φ 22	267	65
150	6	444	320	269.7	216	37	12 x φ 25	305	90
200	8	533	380	330.2	270	41	16 x φ 29	368	175
250	10	622	445	387.4	324	48	16 x φ 32	394	210
300	12	711	520	450.8	381	51	20 x φ 32	445	286
350	14	838	585	514.4	413	54	20 x φ 35	470	400
400	16	864	650	571.5	470	57	24 x φ 35	533	550
450	18	978	710	628.8	533	60	24 x φ 35	584	700
500	20	1016	775	685.8	584	64	24 x φ 41	610	860
600	24	1346	915	812.8	692	70	28 x φ 44	860	1931
650	26	1346	970	876.3	749	79	28 x φ 44	930	2375
700	28	1499	1035	939.8	800	86	28 x φ 44	1163	2660
750	30	1594	1095	996.9	857	92	28 x φ 48	1270	3230

尺寸数据 Dimensions data

DN	DN/in	L	D	D <sub>1</sub>	D <sub>2</sub>	b	z x φ d	H	重量/kg
600(Lb)									
50	2	292	165	127.0	92	25	8 x φ 19	203	34
65	2 1/2	330	190	149.4	105	29	8 x φ 22	229	45
80	3	356	210	168.1	127	32	8 x φ 22	235	63
100	4	432	273	215.9	157	38	8 x φ 25	286	114
125	5	508	330	266.7	186	44	8 x φ 29	292	160
150	6	559	355	292.1	216	48	12 x φ 29	330	207
200	8	660	420	349.2	270	56	12 x φ 32	381	387
250	10	787	510	431.8	324	64	16 x φ 35	457	580
300	12	838	560	489.0	381	67	20 x φ 35	584	778
350	14	889	605	527.0	413	70	20 x φ 38	635	986
400	16	991	685	603	470	76	20 x φ 41	584	1320
450	18	1092	745	654.1	533	83	20 x φ 44	752	1620
500	20	1194	815	723.9	584	90	24 x φ 44	975	2120
600	24	1397	940	838.2	692	102	24 x φ 1	1111	3100



尺寸数据 Dimensions data

DN	DN/in	L	D	D <sub>1</sub>	b	z × φd	H	重量/kg
900(Lb)								
50	2	372	215	15.1	95.2	8 × φ25	216	40
65	2½	422	245	190.5	108.0	8 × φ29	254	60
80	3	384	240	190.5	123.8	8 × φ25	292	88
100	4	461	290	235.0	149.2	8 × φ32	318	122
125	5	562	350	279.4	51	8 × φ35	344	150
150	6	613	380	317.5	56	12 × φ32	368	200
200	8	740	470	393.7	64	12 × φ38	432	230
250	10	842	545	469.9	70	16 × φ38	546	860
300	12	969	610	533.4	79	20 × φ38	660	1390
350	14	1029	640	558.8	86	20 × φ41	782	1380
400	16	1130	705	616	90	20 × φ44	838	1900
1500(Lb)								
65	2½	419	245	190.5	41.5	8 × φ29	193	57
80	3	470	265	203.2	48.0	8 × φ32	246	66
100	4	546	310	241.3	54.0	8 × φ35	288	87
125	5	673	375	292.1	73.5	8 × φ42	324	108
150	6	705	395	317.5	83.0	12 × φ39	373	175
200	8	832	485	393.7	92.9	12 × φ45	466	173
250	10	991	585	482.6	108.0	12 × φ51	536	216
300	12	1130	675	571.5	124	16 × φ54	857	-
350	14	1257	750	635	133	16 × φ61	950	-
400	16	1384	825	704.9	146	16 × φ67	1020	-

尺寸数据 Dimensions data

DN	DN/in	L	D	D <sub>1</sub>	b	z × φd	H	重量/kg
2500(Lb)								
65	2½	508	265	196.8	57.5	8 × φ32	255	98
80	3	578	305	228.6	67	8 × φ35	315	120
100	4	673	355	273.0	76.5	8 × φ42	360	240
125	5	794	420	323.8	92.5	8 × φ48	418	410
150	6	914	485	368.3	108	8 × φ54	465	590
200	8	1022	550	438.1	127	12 × φ54	555	990
250	10	1270	675	539.7	165.5	12 × φ67	630	1250
300	12	1422	760	619.3	184	12 × φ73	1000	5500

